



## The L-shaped belt conveyor

Sturdy ■ Reliable ■ Easy to clean



### Characteristics:

- ▶ Conveyor with plastic hinge plate belt and plastic slats
- ▶ Lamellar sidewalls
- ▶ Also ideal for small parts
- ▶ Solid and sturdy steel construction, also available in stainless steel on request
- ▶ Automatic interruption of operation if any obstruction occurs
- ▶ Mobile design

### Options:

- ▶ Versatile adjustment of material hopper
- ▶ Distributor chute
- ▶ Transparent cover
- ▶ Adjustable conveyor belt speed
- ▶ Sequential control system (user-definable run- and stoptimes)

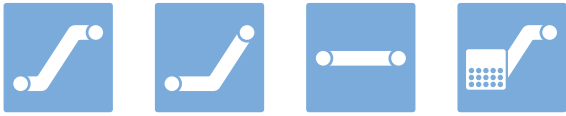

Components for your automation.

# The component System



## Choose the configuration you require:

Length of feeding section  $L_A$ : \_\_\_\_\_ mm      Length of inclined section  $L_S$ : \_\_\_\_\_ mm

Band width for plastic plate belt:

116 mm     200 mm     216 mm     300 mm

316 mm     400 mm     416 mm     500 mm

Width of belt: \_\_\_\_\_ mm

Angle  $\alpha$ :       45°     60°

Motor:       Hollow shaft     Drum

Height of slats:     20 mm     30 mm     \_\_\_\_\_ mm

Belt design: \_\_\_\_\_

Conveyor belt speed:     4 m/min.     9 m/min.     12 m/min.

Options:       Side railing     Controllable     Sequential control system

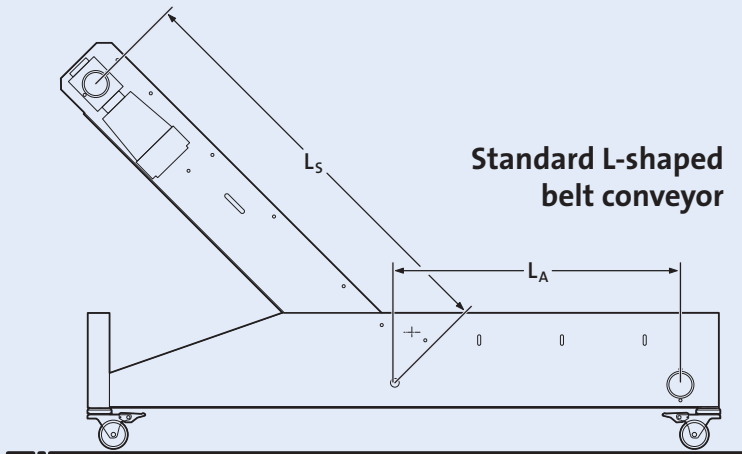

**Configuration:**  
400 V, 3 Ph., 50 Hz • 5 m connecting cable  
CEE plug 16 A • mobile • color RAL 7035

## A+L-belt conveyors in different designs:

 Z-shaped belt conveyors

 Horizontal belt conveyors

 L-shaped belt conveyors

 Belt conveyors with storage bin

Firm stamp

Subject to technical modifications. Availability and errors excepted · 230/10.10/GB