

The bunker belt conveyor

Sturdy ■ Reliable ■ Easy to clean



Characteristics:

- ▶ Belt conveyor with plastic hinge plate belt and plastic slats
- ▶ Lamellar sidewalls
- ▶ Also ideal for small parts
- ▶ Solid and sturdy steel construction, also available in stainless steel on request
- ▶ Automatic interruption of operation if any obstruction occurs

Options:

- ▶ Customized storage bin
- ▶ Distributor chute
- ▶ Transparent cover
- ▶ Adjustable conveyor belt speed
- ▶ Sequential control system (user-definable run- and stoptimes)

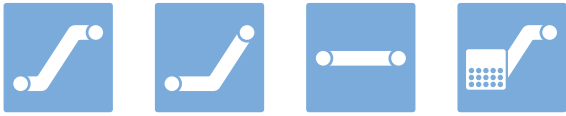

Components for your automation.

The component System



Choose the configuration you require:

Filling level L_{EH} : _____ mm Height of discharging section L_{AH} : _____ mm

Length of inclined section L_S : _____ mm

Band width

for plastic plate belt: 116 mm 200 mm 216 mm 300 mm
 316 mm 400 mm 416 mm 500 mm

Width of belt: _____ mm

Motor: Hollow shaft Drum

Height of slats: 20 mm 30 mm _____ mm

Belt design: _____

Conveyor belt speed: 4 m/min. 9 m/min. 12 m/min.

Options: Side railing Controllable Sequential control system

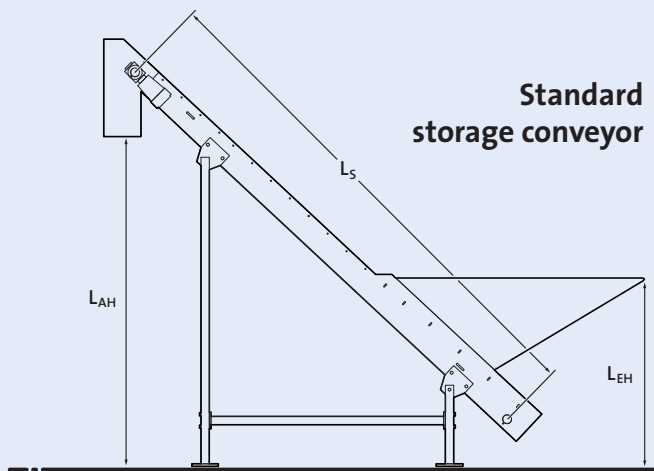

Configuration:

400 V, 3 Ph., 50 Hz • 5 m connecting cable
 CEE plug 16 A • mobile • color RAL 7035

A+L-belt conveyors in different designs:



Z-shaped belt conveyors



Horizontal belt conveyors



L-shaped belt conveyors



Belt conveyors with storage bin

Firm stamp

Subject to technical modifications. Availability and errors excepted · 231/10.10/GB